

CAPACITY	SYMBOL/SERIAL NO.	CIRCUIT DIAGRAM
AC100-240V, 50/60Hz		
28W		

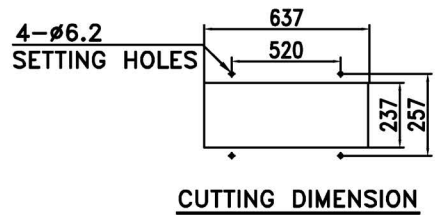
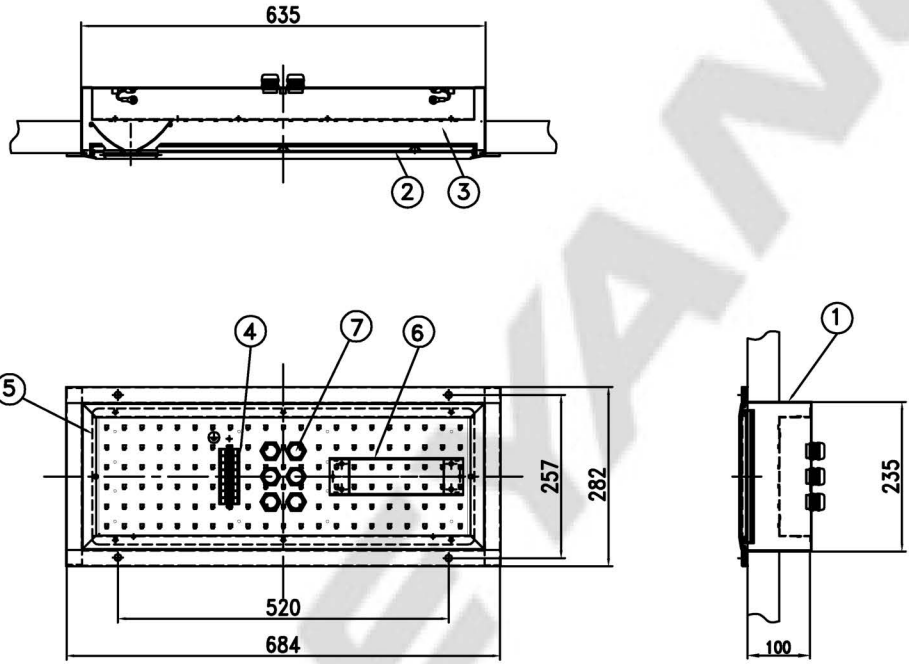

					4	TERMINAL BLOCK	-	1	CLAMPING 7P
7	CABLE GLAND	BRASS	6	OSPGR-R25M (ø9~ø17)	3	LED module	-	1	5,000K
6	DIMMING LED driver	-	1		2	GLOBE	ACRYL	1	
5	LED module BRACKET	STEEL	1		1	BODY	STEEL	1	
NO	NAME OF PARTS	MATERIAL	Q'TY	REMARKS	NO	NAME OF PARTS	MATERIAL	Q'TY	REMARKS

APPROVED	B. K. KIM	UNIT	MM	TITLE; NO-GAP LED CEILING LIGHT (DIMMING CONTROL(WHITE)) FOR MARINE USE
CHECKED	J. W. PARK	SCALE	N/S	
DRAWING	H. S. SHIN	COLOR	N-9.3	
DATE	2016.02.01	IP	44	

DAEYANG	MODEL NO.	LEB128WF-0550SNC50D-A	WEIGHT	7.5 Kg
	DWG NO.	LO1150069	SHEET NO.	59

NO	CONTENT	DATE	REVISER	APPROVAL
△				
△				
△				

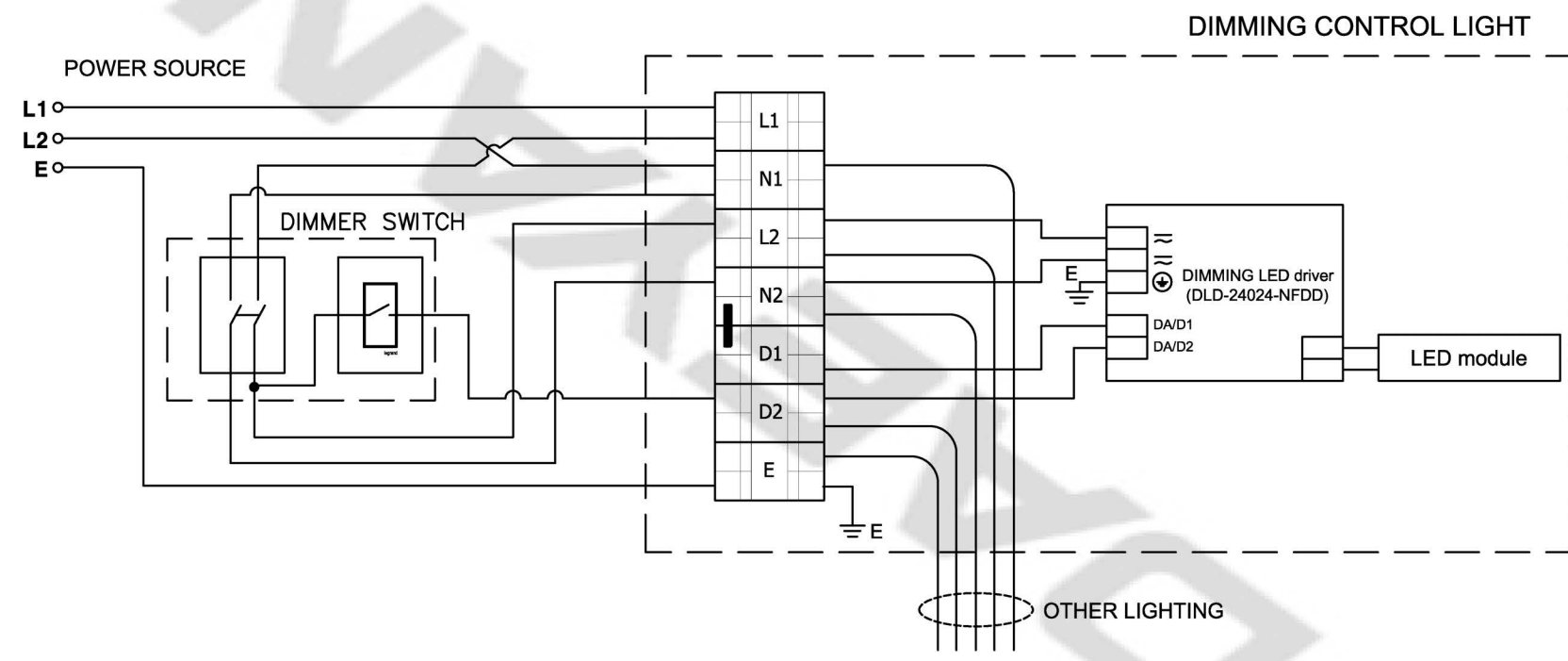

TITLE: LEB128NF-0550SNC50D-A Connection Diagram	SCALE	1/1	UNIT	MM	NO.	REVISED
	PROJECT METHOD		WEIGHT	KG	△	
	APPROVED	B. K. KIM			MATERIAL	ASS'Y
	CHECKED	J. W. PARK			DWG NO.	
	DRAWN	H. S. SHIN			SHEET NO.	59-A
	DATE	2016. 02. 01				